



**Laboratory Equipment Pty Ltd**

# **INSTRUCTION MANUAL FOR ULTRA LOW FREEZER**

*Laboratory Equipment Pty Ltd*  
*"Proudly Australian Owned and Operated."*  
26 Farr Street, Marrickville NSW 2204  
Phone +61 02 95602811 Fax +61 02 95606131  
[www.labec.com.au](http://www.labec.com.au)

·Please read the operation instructions before installing and using this product and keep it safe for reference.

·Please observe the operating instructions and precautions in the directions.

·If a fault occurs, do not repair it yourself or send it to a maintenance department which is unauthorized by our company. Please contact Labec who can organize a suitable service technician.

## **Main performance and characteristics of the product**

Thermal insulating door and secondary seal doors are adopted for use convenience. The loss of refrigeration capacity is reduced and the energy consumption is saved.

Air-cooled condensers provide good heat dissipation and fast refrigerating speed.

Stainless steel inner and tube-in-sheet evaporator are adopted. Things can be put in or taken out easily. The refrigeration effect is good and the freezer can be cleaned easily.

Import microcomputer temperature controllers are adopted for accurate temperature control. The temperature inside the freezer is displayed digitally. With an elegant appearance, the freezer is convenient to use. Users can regulate and check the inside temperature and the working state without opening the door.

The microcomputer control is more accurate and safer.

The system is equipped with a safety protection device for ensuring the safe and reliable operation of the system.

The refrigerating system is manufactured with all imported parts which provide good reliability and long service life to the system.

## **II Precautions**

The sign of “” means the place is dangerous to human bodies, or the use pattern is harmful to products, or alarm users should pay special attention to this.

 : It is strictly prohibited to unpack the outer packing case for transportation.

The ultra low temperature freezer should be used under the environmental temperature of 10°~30°. It is suggested to use it under the environment with air conditioning.

 : The slant angle of the body of the ultra low temperature freezer should not be larger than 45° in

transportation to avoid faults of the compressor or the system.

△ : After unpacked, the freezer should be placed on flat and firm ground near to the power socket.

: Do not put it near a heat source and avoid the direct light

: The ultra low temperature freezer should be stored in a dry and draft free

room without corrosive gasses in the atmosphere.

△ : If the ultra low temperature freezer has to be stopped for a long period, it should be cleaned inside and outside and then covered properly with a plastic housing.

△ : The power supply is 198V ~ 242V/50Hz. If the voltage is unstable, please equip a power regulator which is above 3000VA and please use it alone.

△ : It is necessary to provide an individual one-phase three-hole socket and proper fuse for the ultra low temperature freezer.

△ : The ultra low temperature freezer must be provided with reliable independent ground wire. The ground wire cannot be connected to a gas pipe, stem heating pipe or water pipe and the zero line of single-phase source should not be taken over as well.

△ : If the power connect wire has to be lengthened, the sectional area of the conductor is larger than or equals to 1.5mm. The conductor can be single-stranded or multi-stranded. It is strictly prohibited to use a multipurpose socket for connection.

△ : The ultra low temperature freezer cannot lean against the wall. The space of at least 30 cm should be left at the machine room for normal running of the system.

△ : No water is to be allowed to be splashed on the outside body of the ultra low temperature freezer. It is strictly prohibited to splash water into the control panel and the compressor housing. It is also prohibited to use the product in the rain or under an environment with a relative humidity of larger than 85%. Otherwise,

faults such as electric leakage etc. may be caused.

△ : With a continuous operation system, in the case of power failure or machine stopping the ultra low temperature freezer should not be restarted until after five minutes to prevent the compressor or the system from being damaged.

△ : The key of the ultra low temperature freezer should be kept out of the reach of children to avoid accidents.

△ : Inflammable, explosive and volatile dangerous articles, acid and alkali etc. with strong corrosiveness are never allowed to be put in the ultra low temperature freezer.

△ : The ultra low temperature freezer cannot be used in inflammable and explosive gas environments. Be sure not to spray combustibles such as paint, coating etc. to avoid fires.

△ : The door should be closed tight. Otherwise, the normal operation and usage of the system may be affected.

△ : The service environment pollution grade of the ultra low temperature freezer is grade 2.

### **III Range of application**

The ultra low temperature freezer is provided to departments of medicine, health, medical treatment, food, chemical industry, scientific research etc. for low-temperature freezing, storage, test and sub zero treatment.

### **IV Preparation for use**

·After unpacking, remove all outer packing material.

·Checking standard accessories and data: check and compare the accessories and data with the packing list [ please see related pages of the directions] .

·Please place the ultra low temperature freezer in a proper location [please refer to relevant terms in **Precautions**] .

·It would be best to clean the freezer before use

(please refer to relevant terms in **Maintenance**).

## **V Start and test machine**

·Plug in the socket and switch on the power switch (located at the right side of the temperature controller on the front part of the body). Now the power supply indicator light is on. In order to ensure the normal running of the cryogenic freezer, be sure to use the three-hole socket which is rated above 16A.

·The system will automatically start the compressor, and the refrigeration indicator light is on. The system goes into a refrigeration cycle state.

·After the power has been supplied for a period of time, the temperature inside the freezer decreases, which indicates the refrigerating system is working normally.

·Before storing articles, please keep the freezer running in an empty state. When the freezer is stable (it is best to keep it running in an empty state for at least 5 hours) and the inside is cooled completely, the cold store articles can be put in.

## **VI Model and main technical parameters**

Type	Horizontal type
Storage temperature	-40°C ~ -86°C
Rated voltage (v)	220 ~ 240
Frequency (Hz)	50
Electric-shock protection class	Class I Type B
Type of alarm	Sound-light alarm
Climate type	N
Refrigerating fluid	Fluoride-free mix

**Notes: technical parameters in this table are measured at the standard state. Please be subject to the nameplate of the goods freezer without prior notice in case of variation.**

## **VII Functions and basic operation of controller**

**1. Control panel structure:** computer control system is adopted by the ultra low

temperature freezer



## 2. Description

The KLT11IB is designed for heating and cooling applications. The probe temperature is displayed on the bright 3-digit display . The user is able to program different parameters including set point, hysteresis, alarms and probe adjustment using the silicone front keypad. The unit features error or alarm warning, internal buzzer (optional), configurable digital input and password protection. The KL Key input allows easy programming of the parameters. Select between temperature display in °C or °F , display color and 230V ac, 115V ac, 24V ac/dc or 12V ac/dc power supplies.

## 3. Maintenance, cleaning and repair

After final installation of the unit, no routine main maintenance is required.

Clean the surface of the display controller with a soft and damp cloth. Never use abrasive detergents, petrol, alcohol or solvents.

All repairs must be made by authorized personnel.

## 4. List of parameters

	Description	Units	Range	Factory
SP	Set Point	Degrees	r1 to r2	-86
r0	Differential or hysteresis	Degrees	0.1 to 99.9	2.0
r1	Lower value for SP	Degrees	-200 to r2	-86
r2	Higher value for SP	Degrees	r1 to 600	-40
r4	Set Point variation	Degrees	0.1 to 200	3.0
d0	Cooling or heating control	Degrees	Co/Ht	Co
c0	Minimum stopping time	Seconds	0 to 999	0
c2	Output status with probe error	Option	On/OFF	ON
P1	Ambient probe adjustment	Degrees	-99.9 to 99.9	0.0
P4	Decimal point	Option	no/yes	yes
P5	3 wires Pt100	Option	no/yes	yes
E0	Digital input configuration	Option	OFF/AI/ES/H C	OFF
H5	Access code to parameters	Numeric	0 to 255	0
A0	Alarm 1 hysteresis	Degrees	0.1 to 99.9	1.0

A1	Alarm 1 threshold	Degrees	0.0 to 999	0.0
A2	Alarm 1 exclusion time	Seconds	0 to 999	0
A3	Alarm 1 type	Option	OFF/HI/LO	OFF
A4	Alarm 2 hysteresis	Degrees	0.1 to 99.9	1.0
A5	Alarm 2 threshold	Degrees	0.0 to 999	0.0
A6	Alarm 2 exclusion time	Seconds	0 to 999	0
A7	Alarm 2 type	Option	OFF/HI/LO	OFF
A8	Alarm verification time	Seconds	0 to 999	0

## 5. Parameter descriptions

**SP** = Set point. Temperature we wish to regulate the machine (variable from r1 to r2)

**r0** = Differential or hysteresis

**R1** = Lower value for SP

**r2** = Higher value for SP

**r4** = Set point variation for energy saving. If digital input configuration E0 ES this value modify the set point as follows:

If d0=Ht new SP= SP- r4

If d0= Co new SP= SP+ r4

**do** = Cooling or heating control

If d0 = Ht and TS is the temperature of ambient probe:

If TS >= SP the load is disconnected

If TS <= SP- r0 the load is connected

If d0 = Co then:

If TS <= SP the load is disconnected

If TS >= SP+ r0 the load is connected

**c0** = Minimum stopping time of the load

**c2** = Output status with probe error

**P1** = Ambient probe adjustment

**P4** = Decimal point

**P5** = 3 wires Pt100. no = 2 wires, yes = 3 wires

**E0** = Digital input configuration

**OFF** = Digital input disabled

**A1** = External alarm (if input is short-circuited)

**ES** = Energy Saving. Set Point value is modified in r4.

**HC** = if input is short-circuited, it changes to Heat or Cold depending of d0 value.

if d0 = Heat it changes to Cold mode.

if d0 = Cold it changes to Heat mode.

**H5** = Access code to parameters (it is set to 00 from factory)

**A0, A1, A2, A3** = Alarm 1 parameters

If A3=OFF alarm 1 disabled

If A3=HI then a high-temperature alarm is set:

if TS >= SP+A1 the alarm 1 is activated

if TS <= SP+A1-A0 the alarm 1 is deactivated

If A3=LO then a low-temperature alarm is set:

if TS <= SP-A1 the alarm 1 is activated

if TS >= SP-A1+A0 the alarm 1 is deactivated



The alarm 1 is not activated until the time since instrument is turn on is higher than A2

**A4, A5, A6, A7**= Alarm 2 parameters (similar to alarm 1)  
**A8**= Alarm verification time. Time since the alarm situation occurs until its signaling. (It affects to Alarm 1, Alarm 2 and External alarm)

## **6.Parameter programming**

Set Point (SP) is the only parameter the user can access without code protection.

- Press SET . SP text will appear on the display .
- Press SET again. The real value is shown on the display.
- The value can be modified with the UP and DOWN arrows.
- Press SET to enter any new values.
- Press SET and DOWN at the same time to quit programming or wait one minute and the display will automatically exit programming mode.

## **7.Access to all code protected parameters.**

- Press SET for 8 seconds. The access code value 00 is shown on the display (unit comes with code set at 00 from factory).
  - With the UP and DOWN arrows, code can be set to user needs.
  - Press SET to enter the code. If the code is correct, the first parameter label is shown on the display (SP).
  - Move to the desired parameter with the UP and DOWN Keys.
  - Press SET to view the value on the display .
  - The value can be modified with the UP and DOWN arrows.
  - Press SET to enter the value and exit.
  - Repeat until all necessary parameters are modified.
  - Press SET and DOWN at the same time to quit programming or wait one minute and the display will automatically exit programming mode.
- \*The keyboard code can be reset to ZERO by turning off the controller and turning it on again while keeping the SET key depressed.

## **8.Led indication, buzzer and display messages**

The led OUT indicates if the load is connected or not.

In normal operation, the probe temperature will be shown on the display .

In case of alarm or error , the following messages can be shown (the alarm led is ON and buzzer sounds):

- Err = Memory Error.
- ooo = Open Probe Error.
- --- = Short-circuit Probe Error .
- A1H = High temperature alarm 1.
- A1L= Low temperature alarm 1.
- A2H= High temperature alarm 2.
- A2L= Low temperature alarm 2.
- ALE = External alarm.

## 9. Alarm validation

In case of alarm the internal buzzer and alarm led is activated. The display shows the corresponding message. The buzzer and display message can be silenced pressing the SET and DOWN arrows at the same time. If the alarm continues after A8 it is signaling again.

## VIII Schematic circuit diagram

### Wiring Diagram

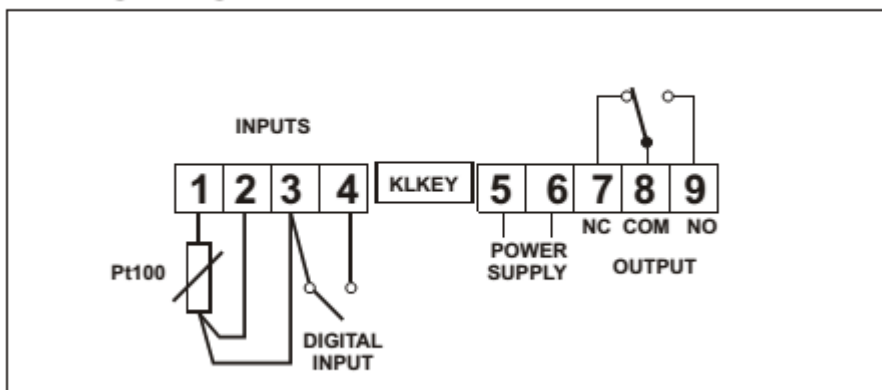

## IX Storage essentials

· Before storing articles, please keep the freezer running in an empty state.

When the freezer is running stably (it is best to keep it running in an empty state for 9 hours above) and the inside is cooled completely, the cold store articles can be put in.

· Articles or other products put in the freezer at one time shouldn't be too much. Proper clearance should be left to help the circulation of the inside cold air.

The refrigerating system of the ultra low temperature freezer is a device used for maintaining low temperature rather than a quick freezing device. If you want to store high capacity (high water-bearing material), precool them in another quick-freezing plant and then store them in the freezer to avoid long-time running without stopping the refrigerating system.

- When the initial storage capacity is large, a method of gradually lowering the temperature set should be adopted. The temperature is lowered by 10°C in every step and then maintained for 1-2 hours until the storage temperature is reached.

- When storing plastic bag products, please note that do not get them close to metal edges to avoid scratches on plastic bags.

## **X Maintenance**

- Body cleaning:** please use non-corrosive neutral cleaning agent to clean the inside and outside surfaces of the ultra low temperature freezer and then use dry cloth to wipe it up.

- △Notes: it is strictly prohibited to use water to directly wash the inside and outside surfaces of the freezer so as not to affect the insulating property of electrical equipment. Boiling water, cleaner, acid, alkali, gasoline, alcohol, benzene, corrosive cleaning agent and scrub-bush are forbidden in cleaning.

- Clean dust on the condenser frequently by banister brush or vacuum cleaner to maintain a good condensing effect.

- Regularly wipe a little talcum powder on the door seal to extend the service life of the sealing strip.

- If the ultra low temperature freezer has been running for a long time, frost may easily accumulate on the door seal, the opening part of the freezer and the side wall inside the freezer. If the frost layer is too thick, the sealing property and the refrigerating property may be affected. Therefore, please defrost regularly and wipe it clean with dry cloth.

- Please use a non-corrosive neutral cleaning agent to clean the inside and outside surfaces of the freezer and then use dry cloth to wipe it up.

- Machine halt:** when stop using the freezer, unplug the power plug, clean it according to the above method, cover it with a plastic bag after natural drying and put it on a ventilated and clean place.

## **XI Non-fault phenomenon**

·Sound of running water can be heard in the ultra low temperature freezer: this is the sound of refrigerating fluid running in the pipeline.

·**Compressor is hot: when the compressor is running, the surface temperature can reach to 70°C ~ 90°C.**

·You may feel a little hot on the two sides of the body (close to the door body) when the freezer is running. That is because the leak proof tube is in the freezer.

·There is condensation on the door seal: in rainy and moist seasons or under the environment with higher relative humidity, there may be condensation on the outer surface of the freezer and the door seal. Then rub dry.

## **XII General fault analysis and removal**

### **The ultra low temperature freezer does not work and there is no display on the controller**

·If the power plug wire is properly connected and the main power supply is plugged in

·If the power switch is turned on

·If the power socket is in good condition

·If the fuse has been burned out

·If the controller is broken or line is damaged: it is necessary to contact the nearby maintenance department for overhaul

### **2. The compressor is running, but the temperature inside the freezer does not decrease**

·The door is opened too often for too long: try to reduce the door-opening time

·The storage capacity is too much: take some out or distribute evenly to keep the air inside the freezer flow

·The condenser is dirty and the heat dissipation is not good: clean the condenser (operate according to relevant terms in **Maintenance**)

·Refrigerant leaks or pipeline is blocked: it is necessary to contact the Labec.

·The condensate fan in the unit is broken: it is necessary to contact Labec.

### **3.Large noise**

·If the outer packing has been all removed

·If the freezer is placed smoothly

·If the back part of the freezer body contacts with the wall: please operate

according to relevant items in **Precautions**.

·The compressor is in abnormal operation only with drone: if the power voltage is within the defined limits, and please operate according to relevant terms in **Precautions**.

·The fan in the machine room makes a lot of noise: the fan is broken or contacts with something. It is necessary to contact nearby maintenance department for overhaul

△Notes: if the ultra low temperature freezer still cannot work normally after being inspected and handled according to the above methods, please contact the maintenance department of our company in time.

## **XIVI After-sale service and commitment**

In order to provide satisfactory after-sale service to consumers using our company's products and maintain the legal rights of the consumers, our company will strictly follow the "Law of PRC on Protection of Consumers' Rights and Interests" and relevant provisions in "Regulations on Repair, Change and Return Responsibilities of Partial Goods" formulated by the State Bureau of Technical Supervision and the Bureau of Finance and provide you with following services basing on the warranty card and the invoice:

The whole machine is guaranteed for twelve months from the purchase date (subject to the invoice).

The whole machine can enjoy life service. And we will charge for repairing in case of one of the following conditions:

·Products with expired guarantee period and products without warranty card and invoice

·Damages due to user's improper transportation and storage or damages caused by the fact that the user does not operate according to the requirements in the instruction book

·Damages caused by the supply voltage exceeding the prescribed limit (187V~242V) or products repaired by a maintenance station which is not authorized by our company

·Nonconformity or alteration of the product warranty card and the purchase invoice

